



# YORK CHAIR INSTRUCTIONS

---

5/32 ALLEN WRENCH  
(1)



2 3/4" SCREW  
(12)

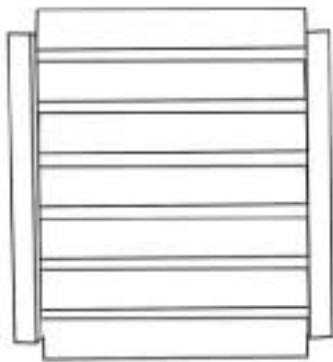

SEAT  
(1)

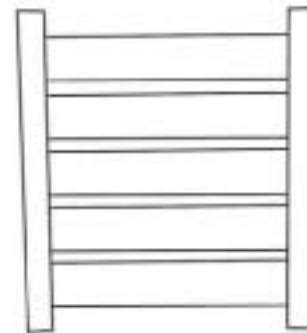

BACK REST  
(1)



CROSS BRACE  
(2)



RIGHT & LEFT LEG  
(1 EACH)



## YORK CHAIR INSTRUCTIONS

### STEP 1:

Place legs on ground as shown in illustration. Attach the cross braces (2) to the right & left legs using (4) 2 3/4" screws.

*\*DO NOT TIGHTEN SCREWS UNTIL INSTRUCTED TO IN FURTHER STEPS.*

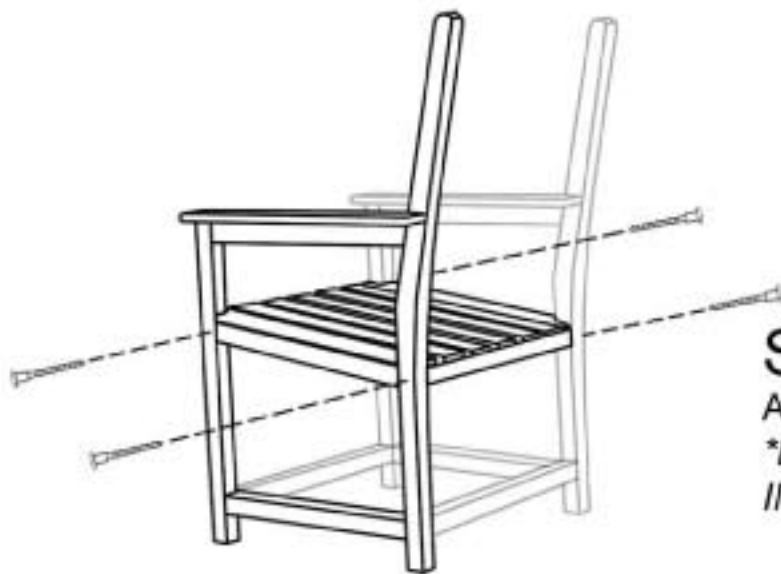
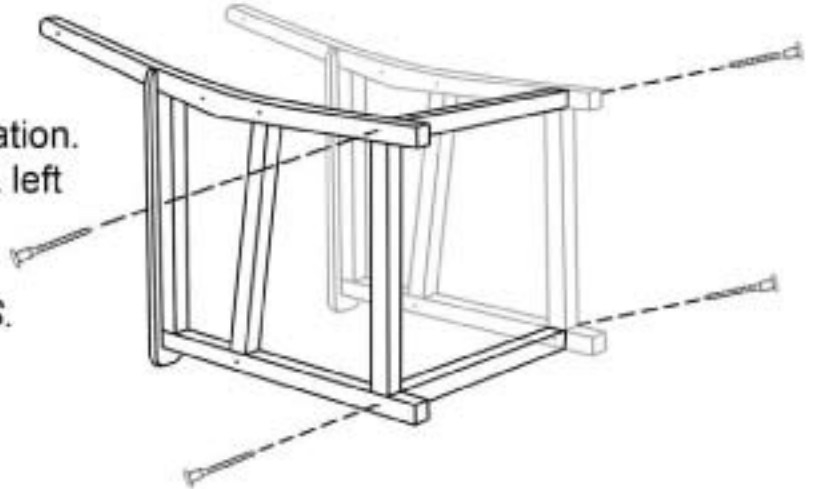

### STEP 2:

Attach seat using (4) 2 3/4" screws.

*\*DO NOT TIGHTEN SCREWS UNTIL INSTRUCTED TO IN FURTHER STEPS.*

### STEP 3:

Attach the bottom of the back rest to the legs using (2) 2 3/4" screws. Make sure that the small staple holes are located at the back of the chair.

*\*DO NOT TIGHTEN SCREWS UNTIL INSTRUCTED TO IN FURTHER STEPS.*





## YORK CHAIR INSTRUCTIONS

### STEP 4:

Rotate the seat back upward and install (2)  
2 3/4" screws.

*\*YOU MAY GO BACK AND TIGHTEN  
ALL SCREWS IN THE PREVIOUS STEPS.*

